



CE

User manual
EP-45G

MASPRA
MASTER SPRAY

Table of contents

1. Safety regulations

- 1.1. Explanation of symbols used
- 1.2. Electrical safety
- 1.3. Electrostatic charge
(spark or flame formation)

2. Summary of Application

- 2.1. Area of operations
- 2.2. Coating materials

3. Device description

- 3.1. Airless procedure
- 3.2. Function of the device
- 3.3. Transport in the vehicle

4. Commissioning

- 4.1. Cleaning of preservatives
- 4.2. Preparation for commissioning
- 4.3. Commissioning

5. Spray technology

6. Handling of the high-pressure hose

7. Work interruptions/pressure drain method

8. Clean Up

- 8.1. General and equipment cleaning from the outside
- 8.2. Intake filter
- 8.3. Clean high-pressure filters
- 8.4. Airless gun clean

Quick Start Manual

page 36

9. Help with faults

10. Maintenance

- 10.1. Clean high-pressure filters
- 10.2. High pressure hose

11. Repairs to the device

- 11.1. Relief valve
- 11.2. Inlet / outlet valve

12. Attachments

- 12.1. Nozzle selection
- 12.2. Maintenance and cleaning of airless reversing nozzles

Warranty

1. Safety regulations for airless spraying

1.1. Explanation of the symbols used

This user manual contains information that the user must thoroughly work through before using the device. In areas marked with the following symbols, work extra carefully and observe all safety instructions.



This symbol indicates a potential danger that can lead to death or serious injury. Here you will find important security information.



This icon indicates a potential danger for you or the device. Under this icon you will find important information on how to avoid damage to the device and risk of injury.



Danger of skin injection



DANGER: Injury by liquids under pressure

A high-pressure liquid, such as that produced by this device, can penetrate the skin and penetrate into the underlying connective tissue, leading to serious injuries and even amputation. Do not treat a splash injury as a harmless cut. In the event of a skin injury caused by coating material or solvent, consult a doctor immediately. For fast, expert treatment, inform the doctor about the coating material or solvent used.



Fire hazard due to solvents and paint vapors



Risk of explosion due to solvents, paint vapors and unsuitable materials



Inhalation of harmful vapors



Notes contain important information that should be noted.

,

Precautions:

- NEVER hold the spray gun on body parts.
- NEVER touch the liquid jet with body parts.
- NEVER touch a leak in the pressure hose with the body.
- NEVER hold your hand in front of the nozzle of the spray gun. Gloves do not provide safe protection against injury from injected liquids.

ALWAYS lock the spray gun trigger, turn off the pump and completely relax the pressure before performing maintenance and cleaning, inspections, nozzle changes or similar work or leaving the device unattended. Even after switching off the engine, the device is still under pressure. The valve PRIME / SPRAY (relief/bypass/pre-fill / spray valve) must stand in its relief /target positions to relax the system pressure.

- ALWAYS put on the nozzle guard when spraying work is carried out. The nozzle protection represents a certain protection, but is primarily intended as a warning device.
- ALWAYS remove the spray nozzle before cleaning or rinsing the system.
- NEVER use a spray gun without a functional trigger lock and without a protective bar.
- All accessories must be approved for at least the maximum operating pressure range of the sprayer. These include spray nozzles, spray guns, extensions and hoses.

**Danger: High pressure hose**

Due to wear, buckling and inappropriate use, leaks can form in the paint hose. Through a leak, fluid can be injected into the skin. Thoroughly check the hose before use.

Precautions:

- Avoid sharp bending or bending of the high-pressure hose, smallest bending radius about 20 cm.
- Do not run over the high-pressure hose, as well as protect against sharp objects and edges.
- Replace the damaged high-pressure hose immediately.
- Never repair a defective high-pressure hose yourself!
- Electrostatic charging of the spray gun and high-pressure hose is discharged via the high-pressure hose. Therefore, the electrical resistance between the connections of the high-pressure hose must be equal to or less than one megaohm.
- For reasons of function, safety and service life, use only MASPRA-Original-replacement high pressure hoses.
- Before each use, check all hoses for incisions, leaks, chafing points or curved surfaces. Check the clutches for integrity and firm fit. Replace hoses immediately if any of the above faults are detected. Never repair a paint hose. Replace a defective hose with a grounded high-pressure hose.
- Be sure to lay spray hoses in such a way that the risk of slipping, tripping and falling over is minimized

Warning!



Attention: Risk of injury due to injection!

Airless devices develop extremely high spray pressures.



Never bring fingers, hands or other body parts into contact with the spray jet!

Never point the spray gun at yourself, people and animals.

Never use the spray gun without spray jet contact protection.

Do not treat a splash injury as a harmless cut.

In the event of a skin injury caused by coating material or solvent, consult a doctor immediately for fast, expert treatment.

Tell the doctor about the coating material or solvent used.

2

According to the operating instructions, the following points must be observed before each commissioning:

1. Faulty devices must not be used.
2. Securing the spray gun with a safety lever on the trigger guard.
3. Ensure grounding.
4. Check the permissible operating pressure of the high-pressure hose and spray gun.
5. Check all connecting parts for tightness.

3

Instructions for regular cleaning and maintenance of the device must be strictly adhered to.

Before all work on the device and at every break from work, observe the following rules:

1. Spray gun and high-pressure hose pressure relief.
2. Securing the spray gun with a safety lever on the trigger guard.
3. Turn off the device.

Pay attention to safety!

**Hazard: Explosion and fire hazard**

Flammable vapors, such as Fumes from solvents and paints can ignite or explode in the work areas.

Precautions:

- Do not process materials with a flash point below 38 °C (100 °F). The flash point is the temperature at which a liquid develops so many vapors that they can ignite.
- Do not use the device in production facilities that are covered by the Explosion Protection Ordinance.
- Ensure good extraction and supply of fresh air so that no flammable fumes accumulate in the spray area.
- Exclude all ignition sources such as sparks from electrostatic discharge, electrical appliances, open flames, ignition flames, hot objects and sparks by closing and disconnecting power cords or actuating work light switches.
- Do not smoke in the spray area.
- Place the sprayer at a sufficient distance from the object to be sprayed in a well-ventilated area (use an extension hose if necessary). Flammable fumes are often heavier than air. The area above the ground must be particularly well ventilated. The pump contains parts in which arc formation cannot be ruled out and which ignite vapours through sparks.
- The objects to be sprayed and the equipment in the spray area must be carefully grounded to avoid sparks caused by electrostatic discharges.
- Use only conductive or grounded high-pressure liquid hoses. The spray gun must be grounded via the hose connections.
- The power cord must be connected to a protective contact circuit (for electrical appliances only).
- To flush the device, always spray into a separate metal container with low pump pressure and removed spray nozzle.

Hold the spray gun firmly against the wall of the container to ground the container and prevent sparks from electrostatic discharges.

- Comply with the warnings and regulations of the manufacturer of the solvents and materials. For safe use, please refer to the safety data sheet and the technical specifications of the painting material.
- To rinse the device, always work with the lowest possible pressure setting.
- When cleaning equipment with solvent, it must not be injected or pumped into a container with a small opening (sheet pile hole). Hazard due to the formation of an explosive gas/air mixture. The container must be grounded.
- Do not use any colors or colors. Solvents containing halogenated hydrocarbons, such as chlorine, bleach, anti-mold agents, methylene chloride and trichloroethane. They are not compatible with aluminium. Contact the supplier of the coating regarding the compatibility of the material with aluminium.



Hazard: Dangerous fumes

Paints, solvents and other materials can be harmful to health when inhaled or in contact with the body. The fumes can cause severe nausea, fainting and poisoning.

Precautions:

- Wear respiratory protection during spraying work. Work through all the instructions supplied with the face mask so that the face mask also offers the desired protection.
- A respirator must be provided to the user (professional and cooperative rules "Rules for the use of respiratory protective devices" (BGR 190).
- Wear safety goggles.
- To protect the skin, protective clothing, gloves and possibly skin protection cream are required (BGR 197 "Use of skin protection"). The regulations of the manufacturers are observed with regard to the treatment materials, solvents and cleaning agents during preparation, processing and equipment cleaning.

**Danger: General**

Can cause serious personal or property damage.

Precautions:

- Comply with all local and state regulations on fire protection, operation and ventilation.
- When the shutter release is pressed, the spray gun pulls to the side. This force effect of the spray gun is particularly strong when the nozzle has been removed and high pressure has been set at the pump. When cleaning with the nozzle unscrewed, therefore set the pressure regulator to the lowest pressure.
- Use only manufacturer-approved parts. When using parts that do not meet the minimum technical requirements, the user bears all risks and all liability. This also applies to the safety devices of the pump.
- ALWAYS follow the manufacturer's instructions for the

safe handling of paints and solvents.

- Wipe up spilled materials and solvents immediately to avoid slipping.
- Wear hearing protection. This device can produce a sound pressure above 85 dB(A).
- Never leave the device unattended. Keep children or other persons who are not familiar with the operation of the compressed airless sprayer away from the device.
- Do not splash outdoors on windy days.
- The device including all liquids (e.B. Hydraulic oil) must be disposed of in an environmentally friendly manner.

1.2. Electrical safety

Electrical appliances must be grounded. In the case of an electrical short circuit, grounding reduces the risk of electric shock because the residual current is dissipated via the protective conductor. This device is equipped with a power cord that has a safety plug. Connection to the power grid only via a special supply point, e.B. via a residual current protection device with $INF \leq 30 \text{ mA}$.



HAZARD — Have work or repairs to the electrical equipment carried out only by an electrician. No liability is assumed for improper installation. Turn off the device.

Before all repairs – unplug from the socket.

Appliance cleaning: Risk of short circuits due to water penetrating into the electrical equipment. Never spray the device with a high-pressure or steam high-pressure cleaner.

Work or repairs on electrical equipment:

These are only carried out by an electrician. No liability is assumed for improper installation.

**1.3. Electrostatic charge
(spark or flame formation)**

Due to the flow velocity of the coating material during spraying, electrostatic charges may occur on the device. These can cause sparks or flames to form when discharged. Therefore, it is necessary that the device is always grounded via the electrical installation. The connection must be made via a properly grounded protective contact socket.

Electrostatic charging of the spray gun and high-pressure hose is discharged via the high-pressure hose. Therefore, the electrical resistance between the connections of the high-pressure hose must be equal to or less than one megaohm.

2. Overview

2.1. Applications

The device performance of the respective MASPRA airless system is designed in a way that the processing of every material that is intended for the system is possible.

Spray Object Examples

In the painting sector, all devices are suitable for all common work, such as: doors, door frames, railings, furniture, wood paneling, fences, radiators and steel parts.

For dispersion and façade paint, high-performance airless devices with a flow rate of at least 2.5 l/min. are recommended.

For spray spatulas, devices with a flow rate of at least 4.5 – 5.0 l/min are suitable.

2.2. Coatings and paint

Usable coatings and paint

Pay attention to airless quality in the coating materials to be processed.

Water-soluble and solvent-based paints and varnishes, two-component coating materials, dispersions, latex paints, release agents, oils, precoats, primers and fillers. Fire protection materials and airless spray spatulas.

The processing of other coating materials only with the consent of MASPRA.

Filtering

Despite the suction filter and plug-in filter in the spray gun, filtering of the coating material is generally recommended. Stir the coating material well before starting work.

Attention: When stirring with motor-driven agitators, make sure that No air bubbles are stirred in. Air bubbles interfere with spraying, can even lead to interruption of operation.

Viscosity

With these devices it is possible to process highly viscous coating materials.

If highly viscous coating materials cannot be sucked in, dilute according to the manufacturer's instructions.

2 K materials

The corresponding processing time must be strictly adhered to. Within this time, rinse and clean the device carefully with the appropriate detergent.

Coating materials with sharp-edged Additives

These exert a strong wearing effect on all material-carrying parts (valves, pistons, sealing packs, high-pressure hose, spray gun and nozzle). As a result, the service life of these parts can be significantly shortened.

3. Device description

3.1. Airless

The main areas of application are the coating of large areas with a high use of materials.

An airless pump sucks in the coating material and conveys it to the nozzle under pressure. At a pressure up to max. approx. 230 bar (23 MPa) pressed through the nozzle, the coating material atomizes. This high pressure causes microfine atomization of the coating material. Since no air is used in this system, this method is called AIRLESS (airless).

This type of spraying has the advantage of the finest atomization, low-fog operation and smooth, bubble-free surfaces. In addition to these advantages, the working speed and the great handiness are to be mentioned.

3.2. Function of the device

For a better understanding of the function, briefly the technical structure;

MASPRA piston airless units are high-pressure piston sprayers driven by electric or petrol motors.

A gear transmission transmits the driving force to a crankshaft. The crankshaft moves the piston of the material feed pump up and down.

Due to the upward movement of the piston, the inlet valve opens independently. When the piston moves downwards, the exhaust valve opens.

The coating material flows under high pressure through the high-pressure hose to the spray gun.

When leaving the nozzle, the layering material atomizes.

The pressure regulator regulates the flow rate and the operating pressure of the coating material.

MASPRA compact hydraulic airless devices are electrically driven diaphragm high-pressure sprayers. The hydraulic pump is driven by a gearbox. A piston is moved up and down, thus requiring hydraulic oil under the diaphragm, which then moves. Due to the downward movement of the diaphragm, the disc inlet valve opens automatically and the coating material is sucked in. During the upward movement of the diaphragm, the coating material is displaced and the ball-exhaust valve opens while the intake valve is closed.

The coating material flows under high pressure through the High-pressure hose to spray gun and becomes at exit atomized at the Duse. The pressure control valve limits the set pressure in the hydraulic oil circuit and thus also the pressure of the coating material.

A change in print when using the same Duse also leads to a change in the amount of atomized ink.

3.3. Transport in the vehicle

Secure the device with a suitable fastener.

NEVER transport a pressurized device!

4. Commissioning

4.1. How to start the first time: Cleaning of preservatives

1. Suction hose or intake pipe and return hose immerse in a container with suitable detergent.
2. Rotate the pressure regulator to minimum pressure.



3. Open bypass valve.

Valve position PRIME (circulation). Counterclockwise rotary knobs



4. Turn on the device.



ON = An / OFF = Aus

5. Wait until detergent comes out of the return hose.

6. Close the relief valve. Valve position SPRAY (spraying). Turn the lever in transverse position.

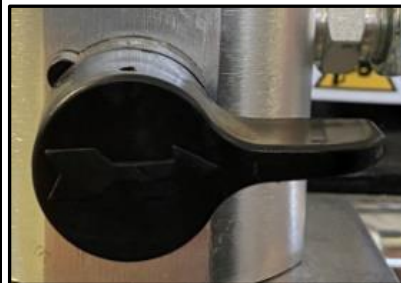

7. Pull the trigger guard of the spray gun.

8. Inject detergent from the device into an open collection container.

4.2. Preparation for commissioning

1. Prepare the color according to the manufacturer's recommendations.
 - Remove dried paint residues.
 - Dilute the paint according to your material manufacturer's instructions.
 - Filter paints and varnishes additionally through a fine nylon filter bag to prevent contamination by foreign particles.
 - These could lead to clogging or damage to your airless device.

2. Remove Nozzle & Nozzle Holder from your spray gun.



3. Unwind your high-pressure hose. Avoid bending or bending the hose.

4. Connect one end of your hose to the gun.



<p>5. Connect the other end to your device. Directly on the HD filter.</p>	
<p>6. Each time before injecting, fill in about 3-5 drops of piston oil at the piston opening at the front side to counteract premature wear.</p>	
<p>7. Make sure the outlet is properly grounded and plug in the plug. Long extension cables can affect performance. Use a longer HD hose instead of another extension cable.</p>	
<p>4.3. Commissioning</p>	

1. Immerse the suction hose or pipe and return hose in the coating material container.

[Alternative: Fill the upper container with material]



2. Turn the pressure regulator counterclockwise to the minimum pressure.

3. Turn the bypass valve **downwards** pointing to the position "PRIME".



4. Turn on the device.



ON = An / OFF = Aus

5. Slowly increase the pressure by turning the pressure regulator clockwise. Wait for your material to leak out of the return hose.

6. Turning the bypass valve to the right to the "Spray" position.



7. Trigger the spray gun several times and inject it into a collection container until the coating material exits the spray gun without interruption.

8. Increase pressure, slowly turn the pressure regulator higher. Check spray pattern, increase pressure until atomization is flawless. Always turn the pressure regulator to the lowest position with still good atomization.



The device is ready to spray!

5. How to spray



Danger of skin injection!

Do not spray without properly mounted nozzle protection. Never press the spray gun extractor without the nozzle being completely set to the spray or de-clogging position. Always press the spray gun exhaust lock before removing, replacing, or cleaning the nozzle.

The key to a good work result is uniform Coating of the entire surface. Move your arm at the same speed and keep the spray gun at an equal distance from the surface. The best spray distance is 20 - 25 cm between the spray nozzle and the Surface.

A

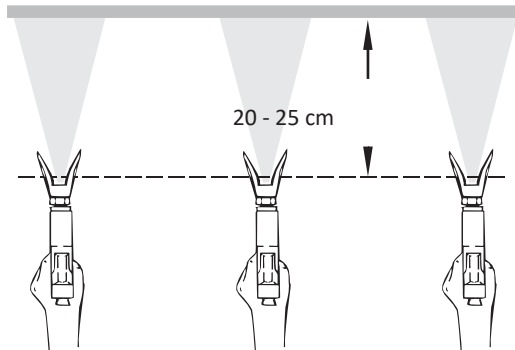

Keep the spray gun parallel to the surface.

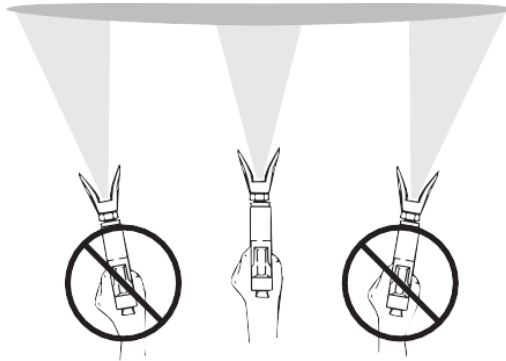
B

This means you have to move your whole arm back and forth instead of just the wrist. Hold the spray gun perpendicular to the surface; otherwise a part of the application area is painted thicker than with other parts

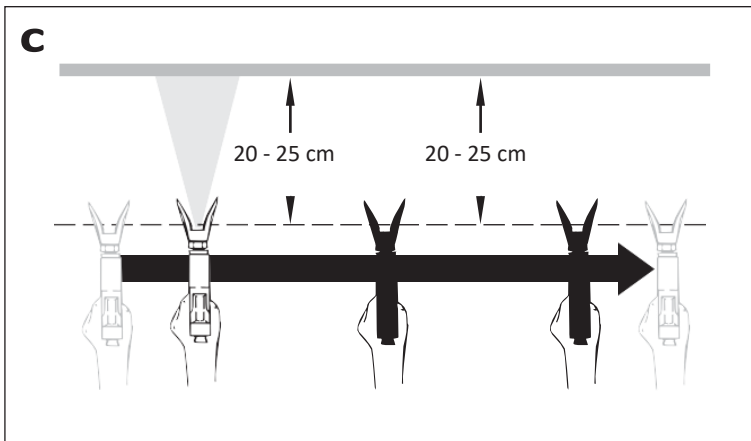

C

Press the spray gun trigger after starting the arm movement. Release the trigger before finishing the movement.

The spray gun should be in motion when pulling and releasing the trigger. Cover each coat of paint at about 30%. This contributes to the uniform application of the painting material.

When very sharp edge zones and strips appear in the spray jet – increase operating pressure or dilute the coating material.

6. Handling of the high-pressure hose

	The device is equipped with a high-pressure hose specially suited for piston pumps.
	Risk of injury due to leaking high-pressure hose. Replace the damaged high-pressure hose immediately. Never repair a defective high-pressure hose yourself!



The high-pressure hose must be treated carefully. Avoid sharp bending or crinkling, smallest bending radius about 20 cm.

Do not run over the high-pressure hose, as well as protect against sharp objects and edges.

Never pull on the high-pressure hose to move the device.

Make sure that the high-pressure hose does not twist. This can be prevented by using a MASPRA spray gun with swivel joint and a hose

reel.

	<p>For the handling of the high-pressure hose when working on the scaffolding, the most advantageous thing has proven to be to always guide the hose on the outside of the scaffolding.</p>
	<p>With old high-pressure hoses, the risk of damage increases. MASPRA recommends replacing the high-pressure hose after 6 years.</p>
	<p>For reasons of function, safety and service life, only use MASPRA original high-pressure hoses.</p>

7. Work break (pressure release)

Always release the pressure on your airless device before cleaning, checking, servicing or transporting it. To do this, follow the instructions below:

1. Turn off the device (OFF) and unplug it.



ON = An / OFF = Aus

2. Turn the bypass valve downwards to the "PRIME" position.



3. Hold the spray gun at a 45° angle against the inside of your bucket. Press the trigger to release any residual pressure.

4. Secure your spray gun.



Pistol secured

Pistol unsecured

NOTE: Leave the bypass valve in the PRIME position until you use the device again.

If there is a suspicion that the nozzle or hose is still clogged and under pressure (be sure to check the pressure gauge / pressure indicator!), please contact the dealer you trust immediately.



Attention

When using quick-drying or two-component coating material, it is essential to rinse the device with suitable cleaning agent within the processing time.

8. Clean up

	Cleanliness is the safest guarantee for trouble-free operation. After completion of the spraying work, clean the device. Under no circumstances should coating materials dry and settle in the device.
	The detergent used for cleaning (only with a flash point above 38° C) must correspond to the coating material.
	<ul style="list-style-type: none"> • Securing the spraygun, see the operating instructions of the spray gun • Clean and disassemble the nozzle.

1. Remove the suction hose/pipe from the coating material.
2. Close relief valve, valve position SPRAY.
3. Turn on the device (ON).



 Attention	In the case of solvent-based coating materials, the container must be grounded.
	Caution! Do not pump or spray into containers with a small opening (sheet pile hole)! See Safety Regulations.

4. Pull the trigger bracket on the spray gun to pump residual coating material from the suction hose/pipe, high-pressure hose and spray gun into an open container.
5. Immerse the suction hose/ pipe with return hose in a container

with suitable cleaning agent.

6. Rotate the pressure regulator to minimum pressure.
7. Open relief valve, valve position PRIME.
8. Suitable detergent pump in circulation for a few minutes.
9. Close the relief valve. Valve position SPRAY.
10. Pull the trigger guard on the spray gun.
11. Pump the remaining detergent into an open container until the device is empty.
12. Turn off the device.

8.1. Equipment cleaning from the outside

	<p>First, unplug the power plug from the socket.</p>
	<p>Short-circuit risk due to penetrating water! Never spray the device with a high-pressure or steam high-pressure cleaner. Do not insert high-pressure hose into solvent. Wipe the outside only with a soaked cloth.</p>

Attention

Wipe the outside of the device with a cloth soaked in suitable detergent.

8.2. Suction screen



A clean intake filter always ensures maximum flow rate, constant spray pressure and proper functioning of the device.

1. Unscrew the filter from the suction-hose/pipe or remove it from the upper container.
2. Clean or replace filters.
Clean with a hard brush and appropriate detergent.



8.3. Clean high-pressure filter (*depending on model)



Clean the filter cartridge regularly. A dirty or clogged high-pressure filter causes a poor spray pattern or a clogged nozzle.

1. Rotate the pressure regulator to minimum pressure.
2. Open relief valve, valve position PRIME.
3. Turn off the device.



Unplug the power plug from the power outlet.

4. Filter housing ideally unscrewed with tape key.
5. Unscrew the filter from the pump assembly by turning it clockwise.
6. Clean all parts with appropriate detergent. If necessary, replace the filter cartridge.
7. Check the O-ring if necessary.
8. Screw the new or cleaned filter into the pump assembly by turning it counterclockwise.
9. Screw in the filter housing and tighten it to the stop with a tape wrench.

8.4. Cleaning the airless spray gun



Clean the spray gun after each use

1. Rinse the airless spray gun at low operating pressure with suitable detergent.
2. Thoroughly clean the nozzle with suitable cleaning agent so that no coating material residues remain.
3. Thoroughly clean the airless spray gun on the outside.

Plug-in filter in the airless spray gun

1. Release the trigger guard from the pistol grip.
2. Use a wrench (size 19) and use it to loosen the handle tube and remove it from the gun head.
3. Pull the old filter out of the spray gun head. Clean or replace it.
4. Insert the new filter with the conical end into the spray gun head first.
5. Slide the handle into the spray gun head until it is stuck and tight.

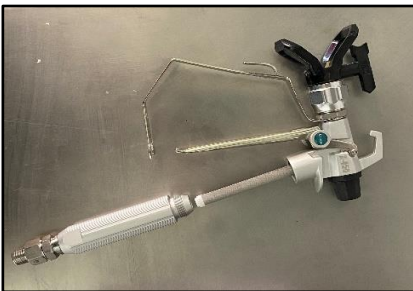

A. Commissioning

1. Dilute paint/varnishes/spray spatulas for ideal processing
2. Select suitable filters (gun, HD filter, suction screen)
 - ➔ Remove all filters for spray spatulas/fabric adhesives
3. Immerse the pump/suction system in the material container
4. Add a drop of **oil** to the flask 1 x a day (front filling opening)
5. or above)
6. Open relief valve (rotary knob)
7. **Pressure regulators to a minimum**
8. On/off switch to ON and wait for the material to pump over
9. **Close relief valve**
10. Turn the pressure regulator to the right until the ideal pressure (colour: 100-120 bar, varnishes 120-140 bar, spray spatula 150-220 bar) is reached

B. Work

1. Pay attention to continuous material supply
2. Switch off immediately as soon as the pump "**draws air**", otherwise there is a risk of damage to the sealing packs
3. Open the relief valve (black rotary knob) and drain the air until material flows again
 - > then continue at A 7.

C. Working break

1. Pressure regulators to a minimum
2. **Open relief valve** (rotary knob)
3. On/Off switch to **OFF**
 - > Continue at A. 5 when starting work

D. Cleaning

1. Flush the pump with clean water* until **the** pump and hose are clean.
2. Pressurize the system with water (approx. 60 bar)
3. **Relief valve** (black rotary knob)
 - open **and close** briefly several times
4. **Switch off the system - open the relief valve.**
5. **Open pistol grip tube and clean the sieve.**
6. **Open high-pressure filters (depending on model) and clean filters.**

* for solvent-containing material: solvent

9. Help in case of malfunctions

Type of malfunction	Possible cause	Measures for eliminating the malfunction
A. Unit does not start	<ol style="list-style-type: none"> 1. No voltage applied 2. Pressure setting too low 3. ON/OFF switch defective 	<ol style="list-style-type: none"> 1. Check voltage supply 2. Turn up pressure control knob 3. Replace
B. Unit does not draw in material	<ol style="list-style-type: none"> 1. Relief valve is set to SPRAY 2. Filter projects over the fluid level and sucks air 3. Filter clogged 4. Suction hose/tube is loose, i.e. the unit is sucking outside air. 	<ol style="list-style-type: none"> 1. Set relief valve to PRIME 2. Refill the coating material 3. Clean or replace the filter 4. Clean connection points. Replace O-rings if necessary. Secure suction hose with retaining clip
C. Unit draws in material, but the pressure does not build up	<ol style="list-style-type: none"> 1. Tip heavily worn 2. Tip too large 3. Pressure setting too low 4. Filter clogged 5. Coating material flows through the return hose when the relief valve is in the SPRAY position 6. Packings sticky or worn 7. Valve balls worn 8. Valve seat worn 	<ol style="list-style-type: none"> 1. Replace the tip 2. Replace the tip 3. Increase the pressure 4. Clean or replace the filter 5. Remove and clean or replace relieve valve 6. Remove and clean or replace packings 7. Remove and replace valve balls 8. Remove and replace valve seat
D. Coating material exits at the top of the fluid section	<ol style="list-style-type: none"> 1. Upper packing is worn 2. Piston is worn 	<ol style="list-style-type: none"> 1. Remove and replace packing 2. Remove and replace piston
E. Unit loses power	<ol style="list-style-type: none"> 1. Pressure setting too low 	<ol style="list-style-type: none"> 1. Increase the pressure
F. Increased pulsation at the spray gun	<ol style="list-style-type: none"> 1. Incorrect high-pressure hose type 2. Tip worn or too large 3. Pressure too high 	<ol style="list-style-type: none"> 1. Only use MASPRA original high-pressure hoses in order to ensure functionality, safety and durability 2. Replace tip 3. Reduce the pressure
G. Poor spray pattern	<ol style="list-style-type: none"> 1. Tip is too large for the coating material 2. Pressure setting incorrect 3. Volume too low 4. Coating material viscosity too high 	<ol style="list-style-type: none"> 1. Replace tip 2. Turn pressure control knob until a satisfactory spraying pattern is achieved 3. Clean or replace all filters. 4. Thin out according to the manufacturer's instructions
H. Pump over-pressurizes and will not shut off	<ol style="list-style-type: none"> 1. Pressure switch defective 2. Transducer defective 	<ol style="list-style-type: none"> 1. + 2. Take unit to a MASPRA authorized service centre

10. Maintenance

10.1. Clean high-pressure filters



The maintenance of the devices should be carried out once a year by the MASPRA service.

1. Check high-pressure hoses, device connection cable and plug for damage.
2. Check the intake, exhaust valve and filter for wear.

10.2. High pressure hose

	With old high-pressure hoses, the risk of damage increases. MASPRA recommends replacing the high-pressure hose after 6 years at the latest .
---	--

11. Repairs to the device

	Turn off the device. Before all repairs – unplug from the socket.
	Be sure to check continuity for grounding. This is mandatory after repairs have been made to the electrical components. Use prescribed gauges to measure continuity between the accessible metal parts of the product and the protective contact of the connector.

11.1. Prime valve



Attention

The valve housing must not be repaired. If this is worn out, it must always be replaced by a new one.

1. Remove the notch pin from the relief valve handle using a 2 mm puncture/sapwood driver.
2. Remove the relief valve handle and carrier.
3. Completely unscrew the valve housing with a roller fork wrench.
4. Make sure the seal fits properly, then screw the new valve housing completely into the color stage housing. Tighten with a roller fork wrench.
5. Align the carrier to the hole in the color stage housing. Slide on the carrier and feed with machine grease.
6. Hole in the valve shaft and in the relief valve handle in agreement.
7. Insert the notch pin and place the relief valve handle in the PRIME/SPRAY position.

11.2. Inlet and outlet valve

1. Remove the screws in the front cover, remove the front cover.
2. Turn on the device (ON) and switch off (OFF) so that the piston is in the lowest stroke position.



Risk of crushing – do not grasp with your fingers or tools between the moving parts.

3. Unplug the power plug from the power outlet.

4. Remove the suction hose/pipe.
5. Unscrew the return hose.
6. Swivel the device 90° backwards for easier work on the material feed pump.
7. Screw the inlet valve housing out of the color stage housing.
8. Remove the lower seal, lower ball guide, inlet valve ball, inlet valve seat and O-ring.
9. Clean all parts with appropriate detergent. Check the inlet valve housing, intake valve seat and intake valve ball for wear, replace parts if necessary.
10. Screw the exhaust valve housing with roller fork wrench out of the piston.
11. Remove the upper ball guide, disc, exhaust valve ball and exhaust valve seat.
12. Clean all parts with appropriate detergent. Check exhaust valve housing, exhaust valve seat, exhaust valve ball, disc and upper ball guide for wear, if necessary, replace parts. Perform assembly in reverse order. Coat the O-ring with machine grease and ensure a correct fit in the intake valve housing.

12. Attachments

12.1. Choosing the right tip

In order to achieve a flawless and rational operation, the selection of the nozzle is of great importance.

In many cases, the correct nozzle can only be determined by a spray test.

Some rules for this:

The spray jet must be uniform.

If strips appear in the spray jet, the spray pressure is too low or the viscosity of the coating material too high.

Remedy: Increase pressure or dilute the coating material. Each pump provides a certain flow rate in relation to the nozzle size:

The following basically applies: **large nozzle = low pressure**
small nozzle = high pressure

Always use the nozzle that matches the performance spectrum of the system: Nozzles that are too small in large airless devices lead to overheating of the electronics!

There is a wide range of nozzles with different spray angles.

12.2. Maintenance and cleaning of Airlessnozzles

Reversenozzle

If a different nozzle design is installed, then clean according to the manufacturer's instructions.

The nozzle has a bore machined with the greatest precision. In order to achieve a long service life, gentle treatment is required. Remember that the carbide insert is not brittle! Never throw nozzle or work with sharp metal objects.

The following points must be observed in order to store the nozzle clean and keep it ready for use:

1. Opening the relief valve, valve positionspraying (circulation).

2. Disassemble the nozzle from the spray gun.
3. Place the nozzle in a corresponding cleaning agent (TipClean) until all coating material residues are dissolved.
4. If compressed air is present, blow out the nozzle.
5. Reinsert the nozzle at the start of work before switching on the device

13. Guarantee

MASPRA warrants that, at the time of delivery to Buyer ("End User"), the Equipment covered by this Warranty is free from defects in materials and fabrication. With the exception of any special, limited or extended warranty that MASPRA has announced, MASPRA's warranty obligation is limited to the free replacement or rectification of those parts which, after PROVEN TO MASPRA in a comprehensible manner, prove to be defective within twelve (12) months of sale to the end user. The warranty only applies if the device has been installed and operated in accordance with MASPRA's recommendations and instructions.

This warranty does not apply in the event of damage or wear and tear due to abrasion, corrosion or improper use, carelessness, accident, improper installation, use of spare parts that do not originate from MASPRA or if changes have been made to the device as a result of which normal use is impaired.

Defective parts must be returned to the authorized MASPRA dealer/subsidiary. All transport costs, including return to the factory, if necessary, are to be borne by the end user and must be paid in advance. Repaired or replaced accessories will be returned at the expense of the end user after advance payment of the transport costs.

THERE IS NO OTHER GUARANTEE OF DEFECTS. MASPRA HEREBY DISCLAIMS ALL AND ALL IMPLIED WARRANTIES, INCLUDING, BUT NOT LIMITED TO, MERCHANTABILITY AND FITNESS FOR A PARTICULAR PURPOSE, TO THE FULLEST EXTENT PERMITTED BY LAW. THE DURATION OF ALL IMPLIED WARRANTIES, WHICH CANNOT BE EXCLUDED, ARE LIMITED TO THE DURATION SET FORTH IN THE EXPRESS WARRANTY. MASPRA IS NOT LIABLE IN ANY WAY BEYOND THE PURCHASE PRICE. LIABILITY FOR CONSEQUENTIAL, INCIDENTAL OR SPECIAL DAMAGES UNDER ANY AND ALL WARRANTIES IS EXCLUDED TO THE EXTENT PERMITTED BY LAW.

MASPRA MAKES NO WARRANTY AND DISCLAIMS ALL STYLISTIC WARRANTIES OF MERCHANTABILITY AND FITNESS FOR A PARTICULAR PURPOSE WITH RESPECT TO ACCESSORIES, EQUIPMENT, MATERIALS AND COMPONENTS SOLD BUT NOT MANUFACTURED BY MASPRA. THOSE COMPONENTS SOLD BY MASPRA BUT NOT MANUFACTURED BY MASPRA (SUCH AS B. GAS ENGINES, SWITCHES, HOSES, ETC.) ARE SUBJECT TO THE WARRANTY OF THE RESPECTIVE MANUFACTURER, IF THESE ARE GRANTED. MASPRA WILL PROVIDE REASONABLE SUPPORT TO BUYER WHEN IT COMES TO CLAIMS FOR BREACH OF WARRANTY.

EU Declaration of Conformity

The declaration of conformity can be ordered from us at any time with the order number MASPRA-CE.

Recycling:

According to the European Directive 2002/96/ EC on the disposal of waste electrical and electronic equipment, and its implementation into national law, this product is not to be disposed of road household waste but must be recycled in an environmentally friendly manner!



Your old equipment will be taken back by us or our representatives and disposed of for you in an environmentally friendly manner. In this case, please contact one of our service centres or us directly.

Notes

Zeichnung A

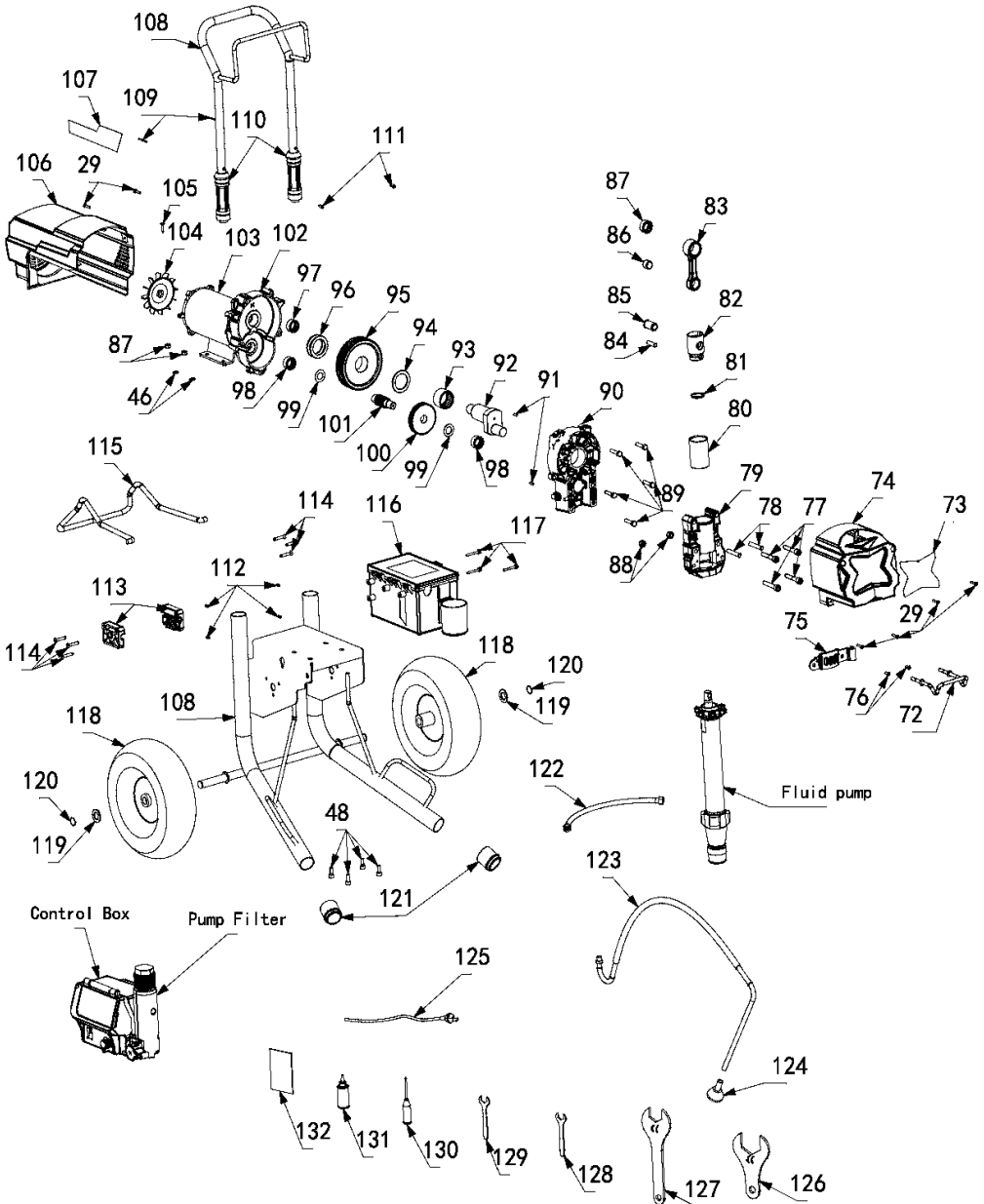

Pos.	A	Description	Part number	Part of	Qty.
29	A	Screw	MA-EP-45#29		10
46	A	Label, control box	MA-EP-45#46		1
48	A	Screw	MA-EP-45#48		6
72	A	Handle	MA-EP-45#72		1
73	A	Label, front	MA-EP-45#73		1
74	A	Cover, pump rod	MA-EP-45#74		1
75	A	Cover, pump rod	MA-EP-45#75		1
76	A	Screw	MA-EP-45#76		2
77	A	Screw	MA-EP-45#77		4
78	A	Pin	MA-EP-45#78		2
79	A	Housing, bearing	MA-EP-45#79		1
80	A	Sleeve, connecting rod	MA-EP-45#80		1
81	A	Spring, sleeve	MA-EP-45#81		1
82	A	Sleeve, connecting rod	MA-EP-45#82		1
83	A	Rod, connecting	MA-EP-45#83		1
84	A	Pin, straight	MA-EP-45#84		1
85	A	Pin, connecting rod	MA-EP-45#85		1
86	A	Bushing	MA-EP-45#86		1
87	A	Bearing	MA-EP-45#87		1
88	A	Screw	MA-EP-45#88		6
89	A	Screw	MA-EP-45#89		5
90	A	Housing, drive	MA-EP-45#90		1
91	A	Pin, housing	MA-EP-45#91		2
92	A	Eccentric shaft	MA-EP-45#92		1
93	A	Needle bearing	MA-EP-45#93		1
94	A	Bearing, thrust	MA-EP-45#94		1
95	A	GEAR, crankshaft	MA-EP-45#95		1
96	A	Washer, thrust	MA-EP-45#96		2
97	A	Needle bearing	MA-EP-45#97		1

98	A	Needle bearing	MA-EP-45#98	2
99	A	Washer, gear, reducer	MA-EP-45#99	3
100	A	Gear, reducer	MA-EP-45#100	1
101	A	Shaft, gear	MA-EP-45#101	1
102	A	Seat, drive housing	MA-EP-45#102	1
103	A	Motor	MA-EP-45#103	1
104	A	Fan, motor	MA-EP-45#104	1
105	A	Screw	MA-EP-45#105	1
106	A	Shield, motor	MA-EP-45#106	1
107	A	Label, side	MA-EP-45#107	1
108	A	Frame, cart	MA-EP-45#108	1
109	A	Pin, spring straight	MA-EP-45#109	2
110	A	Sleeve, cart	MA-EP-45#110	2
112	A	Screw	MA-EP-45#112	4
113	A	Block, support	MA-EP-45#113	2
114	A	M6 Screw	MA-EP-45#114	6
115	A	Frame, support	MA-EP-45#115	1
116	A	Box, tool	MA-EP-45#116	1
117	A	Screw	MA-EP-45#117	3
118	A	Wheel	MA-EP-45#118	2
119	A	Cap, hub	MA-EP-45#119	2
120	A	Clip, retaining	MA-EP-45#120	2
121	A	Cap, leg	MA-EP-45#121	2
122	A	Hose	MA-EP-45#122	1
123	A	Hose, drain	MA-EP-45#123	1
124	A	Deflector, threaded	MA-EP-45#124	1
125	A	Power plug (European plug)	MA-EP-45#125	1
126	A	Adjustable wrench	MA-EP-45#126	1
127	A	Adjustable wrench	MA-EP-45#127	1
128	A	Wrench 17/19	MA-EP-45#128	1
129	A	Wrench 19/22	MA-EP-45#129	1
131	A	Lubricating oil	MA-EP-45#131	1

Zeichnung B

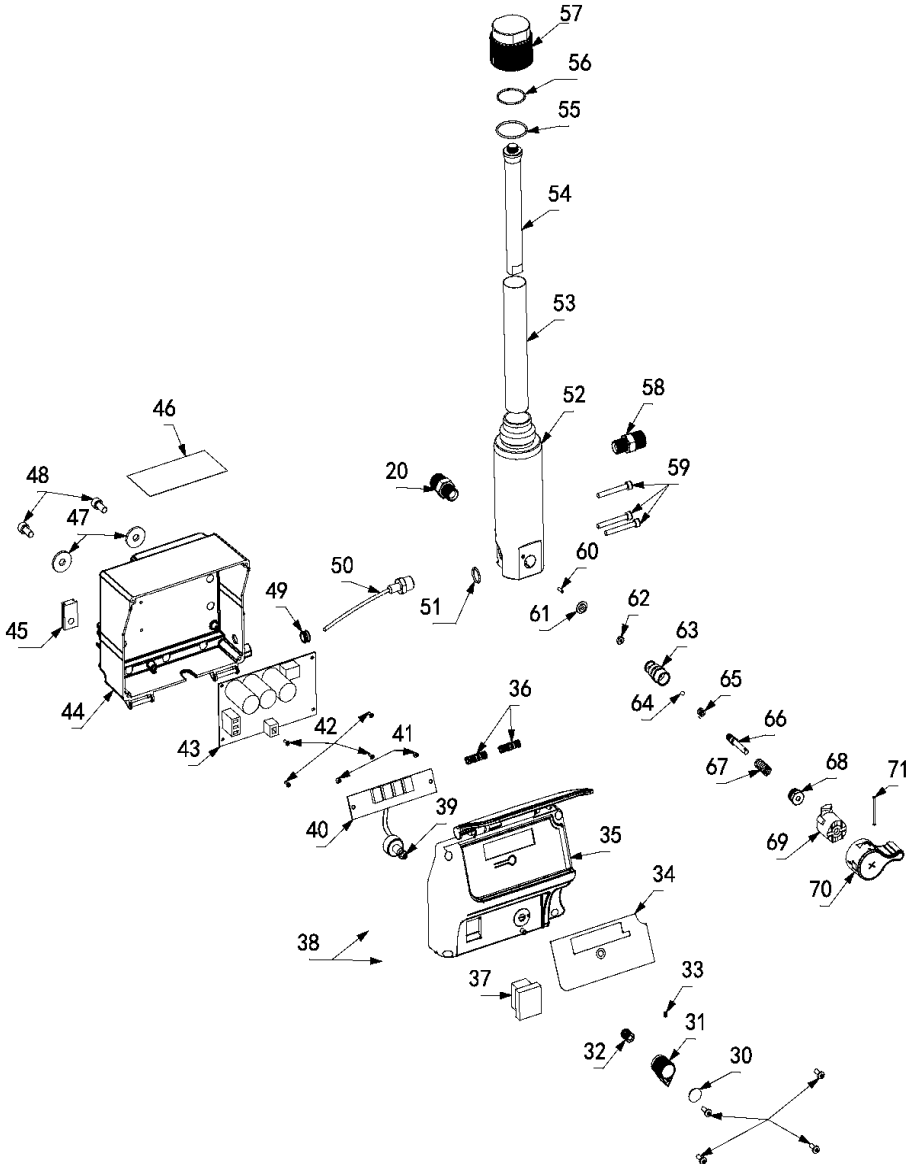

Pos.	B	Description	Part number	Part of	Qty.
30	B	Label, potentiometer	MA-EP-45#30		1
31	B	Knob, potentiometer	MA-EP-45#31		1
32	B	Insert, potentiometer	MA-EP-45#32		1
33	B	Fixing screw	MA-EP-45#33		1
34	B	label, control box	MA-EP-45#34		1
35	B	Box, control	MA-EP-45#35		1
36	B	Spring, control box	MA-EP-45#36		2
37	B	ON/OFF switch	MA-EP-45#37		1
38	B	Power plug	MA-EP-45#38		2
39	B	Potentiometer	MA-EP-45#39		1
40	B	Board, Digital Display	MA-EP-45#40		1
41	B	STP2.9 Screw	MA-EP-45#41		2
42	B	Screw	MA-EP-45#42		4
43	B	Control Board	MA-EP-45#43		1
44	B	Box, control	MA-EP-45#44		1
45	B	Gasket	MA-EP-45#45		1
47	B	M8 Gasket	MA-EP-45#47		6
49	B	Grommet, transducer	MA-EP-45#49		1
50	B	Transducer	MA-EP-45#50		1
51	B	Transducer O-ring	MA-EP-45#51		1
52	B	Manifold housing	MA-EP-45#52		1
53	B	Filter, fluid, 30mesh	MA-EP-45#53		1
54	B	Insert, filter	MA-EP-45#54		1
55	B	O-ring, manifold	MA-EP-45#55		1
56	B	O-ring, cap, manifold	MA-EP-45#56		1
57	B	Cap, manifold	MA-EP-45#57		1
58	B	Nipple, 3/8"x3/8"	MA-EP-45#58		1
59	B	Screw	MA-EP-45#59		3
60	B	Pin, drain valve	MA-EP-45#60	*	1

61	B	Gasket, drain valve	MA-EP-45#61	*	1
62	B	Seat, drain valve	MA-EP-45#62	*	1
63	B	Valve, drain	MA-EP-45#63	*	1
64	B	Ball, drain valve	MA-EP-45#64	*	1
65	B	O-ring, drain valve	MA-EP-45#65	*	2
66	B	Steam, drain valve	MA-EP-45#66	*	1
67	B	Spring, drain valve	MA-EP-45#67	*	1
68	B	Base, drain valve	MA-EP-45#68	*	1
69	B	Base, valve	MA-EP-45#69	*	1
70	B	Handle, valve, drain	MA-EP-45#70	*	1
71	B	Pin, groove	MA-EP-45#71	*	1
*	B	bypass-valv e cpl.	MA-EP-45#BV		

Zeichnung C

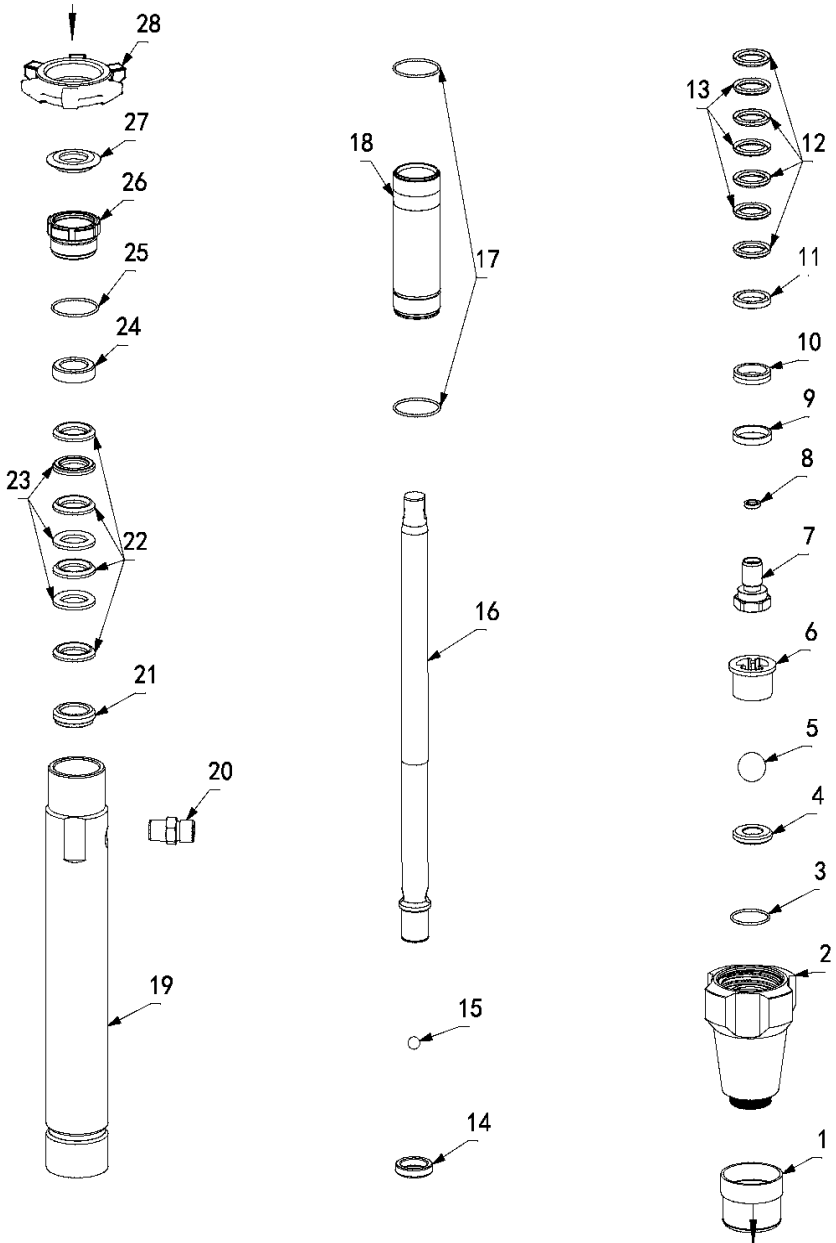

Pos.	C	Description	Part number	Part of	Qty.
1	C	Strainer	MA-EP-45#1		1
2	C	Valve	MA-EP-45#2		1
3	C	O-ring	MA-EP-45#3	*	1
4	C	Seat, carbide	MA-EP-45#4		1
5	C	Ball, inlet	MA-EP-45#5	*	1
6	C	Guide, ball	MA-EP-45#6		1
7	C	Valve, piston	MA-EP-45#7		1
8	C	Seat, piston valve	MA-EP-45#8		1
9	C	Washer, backup	MA-EP-45#9	*	1
10	C	Wiper, piston	MA-EP-45#10	*	1
11	C	Gland, female	MA-EP-45#11	*	1
12	C	V-packing	MA-EP-45#12	*	4
13	C	V-packing, leather	MA-EP-45#13	*	3
14	C	Gland, male	MA-EP-45#14	*	1
15	C	Ball, check	MA-EP-45#15	*	1
16	C	Piston rod	MA-EP-45#16		1
17	C	O-ring	MA-EP-45#17	*	2
18	C	Sleeve, cylinder	MA-EP-45#18		1
19	C	pump housing	MA-EP-45#19		1
20	C	Nipple, 3/8"x3/4"	MA-EP-45#20		2
21	C	Gland, male	MA-EP-45#21	*	1
22	C	V-packing	MA-EP-45#22	*	4
23	C	V-packing, leather	MA-EP-45#23	*	3
24	C	Gland, female	MA-EP-45#24	*	1
25	C	O-ring	MA-EP-45#25	*	1
26	C	Nut, packing	MA-EP-45#26		1
28	C	Nut, retaining	MA-EP-45#28		1
*	C	repair-kit	MA-EP-45#RK		

Gemini GmbH

Rheinstraße 7

D-88046 Friedrichshafen

Tel.: +49 7541 9815615

Fax: +49 7541 9815625

E-Mail: info@gemini-airless.de

www.gemini-airless.de
